

# CHUDONG

Our thermoforming, beyond your imagination

## Worldwide

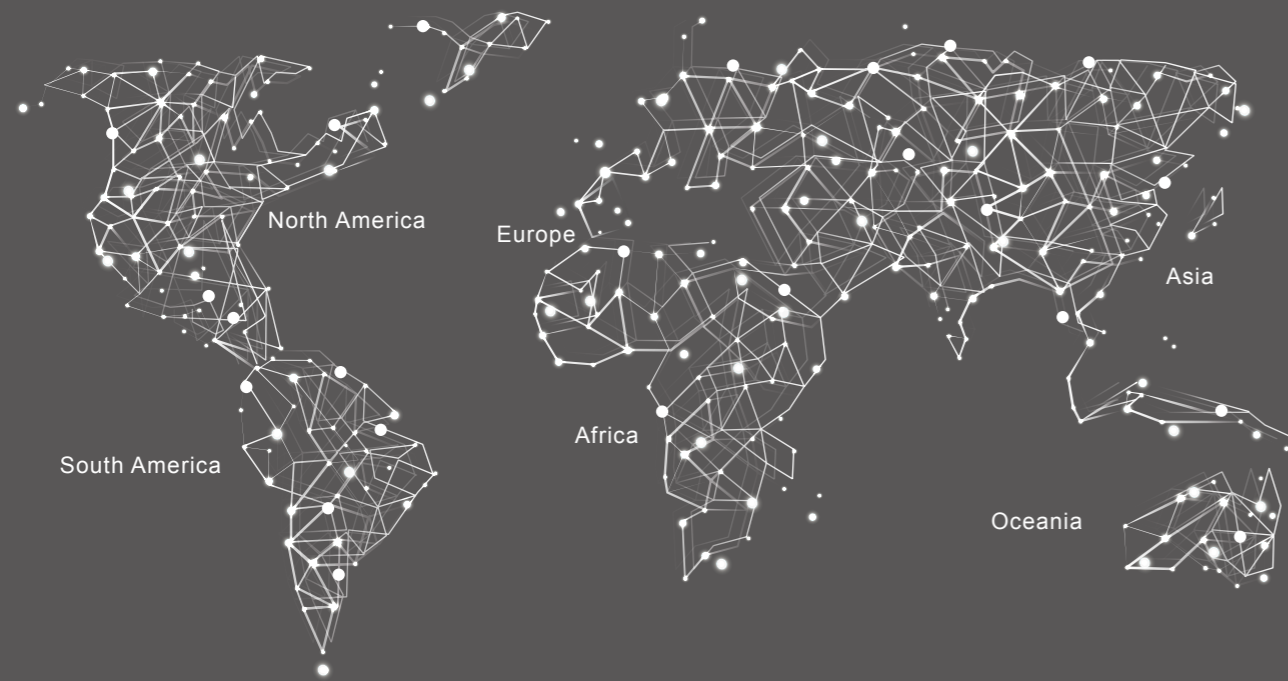

**First in Asia, globally renowned expert in pressure forming!**  
**That is CHUDONG's unchanging goal since establishment.**

CHUDONG is focused on the research, development and manufacture of pressure forming machinery.

We are born of the passionate pursuit for the ultimate pressure forming technology, and have been the leader since our entry into this field.

CHUDONG is able to provide the market with pressure forming technology and service and can share, cutting and stacking all in one go. We are dedicated to the field of pressure forming, exclusively the manufacturing

of pressure forming machinery and equipment for the production of disposable packing for food and beverages.

CHUDONG integrates automatic and smart technologies with pressure forming to develop equipment systems that meet cutting in one station pressure forming machinery and post trim pressure forming machinery, and provide more diverse and flexible pressure forming

solutions so that clients can easily meet the quantitative and ever-changing demands of the market.

In the future, CHUDONG machinery will strive towards even smarter and more diverse pressure forming machinery, to truly become the world-renowned expert in pressure forming, and your reliable long-term partner.



## Automatic Thermoforming Solutions and Skills

Plastic Packing

SL-1220A + SL520

Thermoforming Production Line

### CHUDONG MACHINERY CO. LTD.

Factory. No. 79-79, Waizhong St., Fuxing Township, Changhua County 50660, Taiwan  
Tel. +886-4-779-5888 Fax. +886-4-779-5757 Mail. sales@chu-dong.com.tw



www.chu-dong.com

# Cutting-edge Technology

A combination of conventional devices and advanced control systems

A combination of conventional devices and advanced control systems

- PS (Polystyrene)
- PE (Polyethylene )
- PP(Polypropylene )
- OPS (One Pack Systems)
- PLA (Poly Lactic Acid)
- APET (Amorphous Polyethylene Terephthalate)
- HIPS (High Impact Polystyrene )
- EPS (Expandable Polystyrene)

## Rigid Plastic :



Sushi box



Egg box



Strawberry box



Salad box



Fruit box



Vegetable box

## Foamed Plastic :



Takeout box



Instant noodle bowl



Lunch box

## A global leading brand in smart thermoforming

Our thermoforming, beyond your imagination.

Chudong Machinery Co., Ltd. has the design and manufacture capability for both cutting in one station pressure forming machinery and post trim pressure forming machinery, using the three core values of technique, quality and service to create brand reliability.

Whether it's performance, quality or price of the machinery, Chudong 's high degree of flexibility will comprehensively meet the client's demands, making it a global leading brand in smart pressure forming.

### The strengths brought to you by Chudong:

- Flexible package solutions for various budgets and production needs.
- Fine processing competence fit for all standard and few specific plastics.
- Cold forming under high pressure load for high capacity and low cost.
- A cut of labor and waste via direct retrieval of plastic waste
- Low power consumption due to 30% saving energy and 40% compressed air cutting.
- A central control unit for easy operation and handy maintenance.
- Rich experiences in package equipment with a tailor-made solution for you.

# SL-1220A + SL520 Thermoforming Production Line

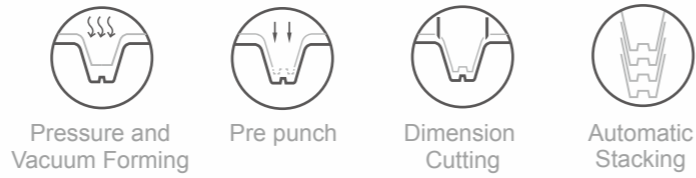

## Exceptional performance Demand-meeting matches

Chudong experienced in machinery making skills over 35 years with the excellent innovation competence can easily offer you the optimal thermoforming production line with the module production system under your budget and terms of and demands for production.



Plan A: Fully Automated System	Thermoforming SL-1220A	Pre Punch SL-520	Dimension Cutting SL-520	Automatic Stacking
Plan B: Fully Automated System	Thermoforming SL-1220A		Dimension Cutting SL-520	Automatic Stacking
Plan C: Semi-automated System	Thermoforming SL-1220A	Automatic Cutting and Stacking Mechanism (SHEET)		Hydraulic Cutting Machine
				Manual

# Patented High-precision Thermoforming Clamping Mechanism

Precise swift innovative quality stable reliable advanced performance

Chudong designed this mechanism in pursuit of the high rigidity and high performance as the highest benchmark in the first place, and has invested vast R&D resources in the core structural design of thermoforming. The high-pressure thermoforming efficacy is achieved by the 4-point clamping

mechanism solely developed by Chudong equipped with the powerful robust clamping capability in combination with the 4-pillar high-rigidity thermoforming mainframe structure. Perfect thermoforming must be done in 0.5 second after clamping, so precision, stability, performance and efficiency of mechanical

operations do matter the most. The Chudong SL series with high-precision mechanisms and high-efficiency control components can make perfect finished items under easy calibration in producing respective materials besides reliable and stable outputs for the maximal effects of our clients.



High rigidity body design

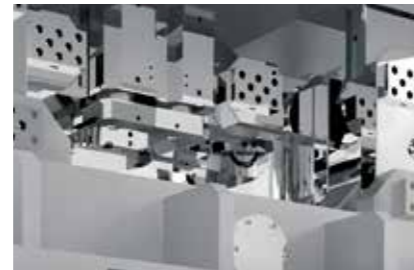

Patented 4-point clamping mechanism

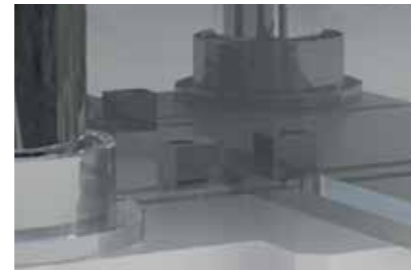

QDC System

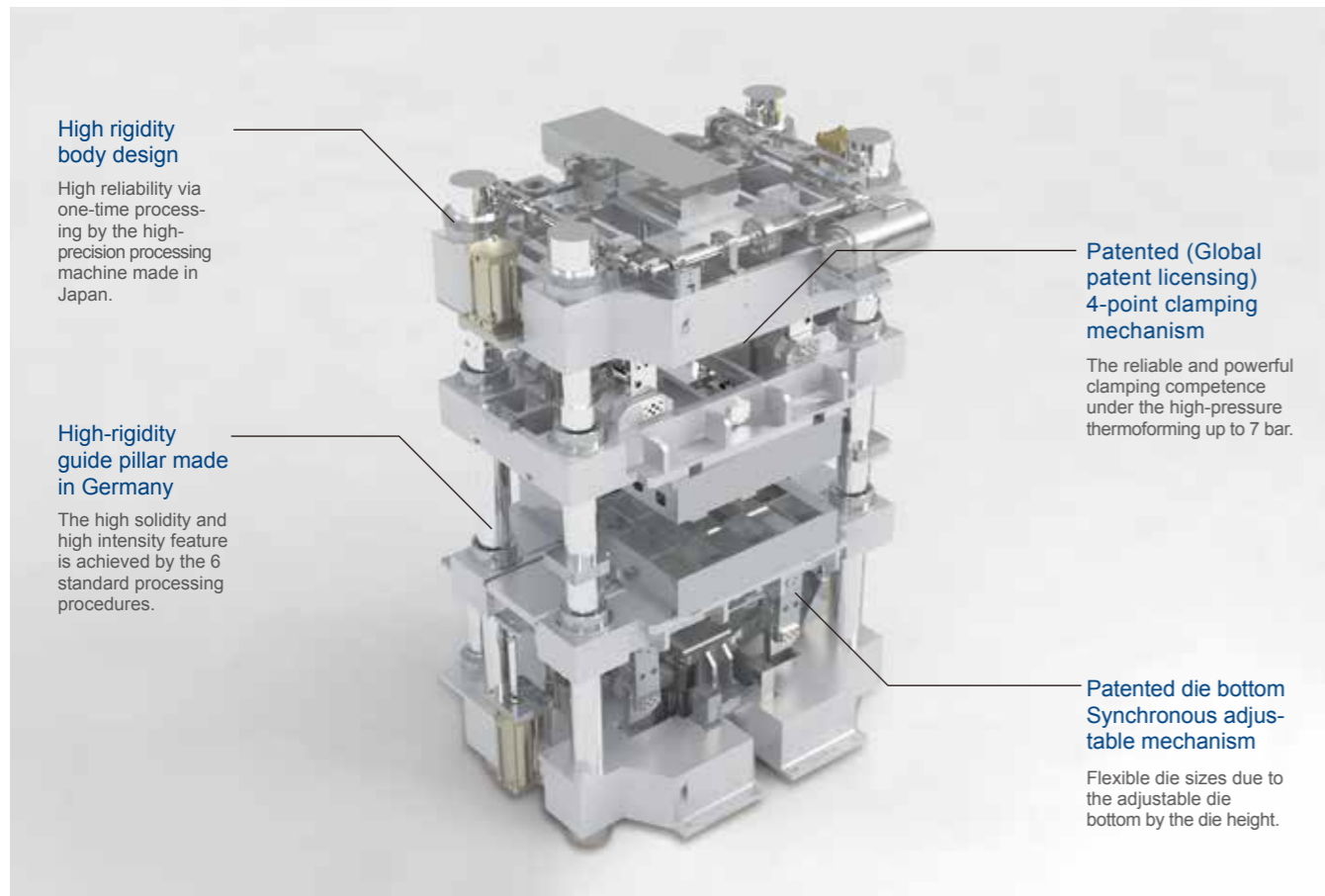

**High rigidity body design**

High reliability via one-time processing by the high-precision processing machine made in Japan.

**High-rigidity guide pillar made in Germany**

The high solidity and high intensity feature is achieved by the 6 standard processing procedures.

**Patented (Global patent licensing) 4-point clamping mechanism**

The reliable and powerful clamping competence under the high-pressure thermoforming up to 7 bar.

**Patented die bottom Synchronous adjustable mechanism**

Flexible die sizes due to the adjustable die bottom by the die height.



**4-pillar High-rigidity Thermoforming Mainframe Structure High-pressure Thermoforming Efficacy of Thermoforming Machinery.**

# Cutting-edge Automatic Thermoforming Technology

10 Strengths you cannot miss.



10 TOP

## 5 Lower temperature forming

Cold forming due to vast pressure power prevents leather from pulling due to overheat. The effects include high-quality forming, energy saving and long life of furnace wires.

## 6 Low power consumption

The efficacy is advanced by vast pressure power and cold forming. The testing proves the production target attained under low power consumption by Chudong-made equipment with 30% power saving and 40% compressed air cutting.

## 7 High-precision thermal control system

Each segment owns its independent thermal control and setting. The yield rate is improved by the precise temperature made up by the SSR PID controller.



## 8 Ample automation / Full automatic production

Chudong has applied automation to each link for full automatic processing from automatic stacking & counting, automatic de-molding and automatic lubrication system to become the benchmark.



## 1 Servo feeding system

Stability and precision kept under high-speed feeding by hardware of the servomotor-driven feeding drum and Japan-made chain and software of the servo control system.



## 2 High pressure power

With the clamping power surmounting the industrial standard, Chudong not only cuts the material thickness via high thermoforming solidity of finished items but also secures exceptional details and ease of thermoforming.



## 3 High rigidity body design

The one-piece body structure made of high-tensile steel make the equipment operate stably and smoothly with low vibration and low noise.



## 4 Long heating oven with segments (optional)

The standard heating oven 3000 mm long helps thermoforming operated well. The heating device by segments 3-5 is optional for flexibility. The thermal control is precise by installing the ceramic heaters made in Germany to upper and lower stoves.



## 9 4-column high-rigidity guide column mechanism

Stable and precise thermoforming and high reproducibility of clamping positioning via the guide column made of top steel in combination with the 4-column structure of the die backer.



## 10 Registration forming function

The registration system for printed materials in need of auto-feeding positioning and forming is optional.

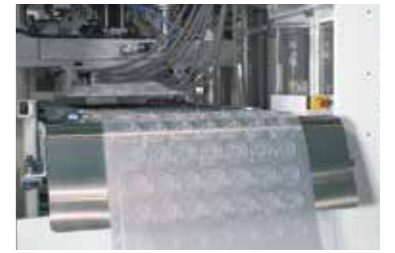

# SL-1220A

## Continuous Thermoforming Machine

High rigidity body for exceptional performance of energy saving

### Features:

- High-rigidity design of machine bed: Integral casting design combined with high-tension steel plate structure offers steady and low noise operation.
- 4-column high-rigidity guide-rod mechanism: guide-rods are made of top grade steel, offering high repetitivity of mold clamping in combination with the 4-column mold structure for steady forming.
- Servo chain feeding system: Japanese chain operated by servo-controller ensures exact precision of high-speed feeding.
- Precision Temperature Control System: Independent temperature control with respective setting for each temperature zone, uses SSR with PID calculus for controlling the temperature, combined with high-speed transmission and control, offers precision adjustment and is convenience for elevated yield.
- Upper and Lower Heating Oven: German made ceramic heater, temperature accuracy can be controlled very well.
- Automatic Lubrication System: Automatic oil feed for slide parts, eliminating any failure resulting from insufficient lubrication

### Optional Functions:

- Third-movement forming: servo-drive mechanism to enable arbitrary positioning and travel corresponding to mold height.
- Rim pre-heating system: pre-heating the material prior to material feeding, facilitating smooth operation of the subsequent process.
- Universal voltage: any voltage is available when specified in advance.
- CE Certificate
- EU version with entire stainless steel system.



Model	SL-1220 A	
Max Forming Area	Max 1200 mm × 1000 mm	Min 840 mm × 600 mm
Max Forming Height	150 mm	
Clamping Force	84 tons	
Max. Width of Material	17.5 tons	

※ We welcome custom-made orders for special request.

※ We reserve the right to modify the specifications of any of the above listed machines without notice.



The continuous thermoforming machine is the fruit of private R&D of technology and experience owned by Chudong in the past 35 years. Each user has been amazed by its high-performance operation. In addition to smooth action, low vibration, low noise and high-speed round-trip positioning control, it does validly raise the output.

The high-speed communication by the ceramic heaters and control system can maximize the effect of precise thermal control and meet the high-standard demand for thermoforming precisely.

# SL-520

## Vertical Trimming Press

Perfect integration of innovation and convention

### Features:

- High torque cam drive mechanism: precision processed machine bed offers high accuracy and powerful cutting torque.
- Servo feed system: servomotor driven steel feed roller offers precision positioning.
- Automatic stack/count function: based on quantity setting, automated stacking and discharge functions effectively reduce manpower consumption.
- Automatic mold release device: Servo-driven mechanism ensures fine-tuning position and speed of mold release.
- HMI system: offers direct parameter setting of 99 functions in the memory.
- Waste-reel device: waste material is automatically reeled, for subsequent chipping on completion of reeling.
- Automatic lubrication system: automatic oil feed for slide parts, totally eliminating part failure resulting from insufficient lubrication.
- HMI system: latest model Siemens control system offers user-friendly operation interface and powerful functionality.
- Alignment mechanism of innovative material: no wrench or spanner required for adjusting material width; fine-tuning achieved quickly and easily.

### Optional Functions:

- Waste reeling and chipping machine: directly chips waste material, saving space for waste storage as well as manpower for waste material handling.
- Photo-sensor tracing function: detects material position for carrying out trans-mold hole punch.
- Universal voltage: any voltage is available when specified in advance.
- CE Certificate



Model	SL-520
Max. cutting dimensions	1100 mm × 400 mm
Max. material height	150 mm
Max. cutting speed	100 spm
Max. cutting travel	220 mm
Cutting capacity	8 tons
Machine weight	about 7500 kg

※ We welcome custom-made orders for special request.

※ We reserve the right to modify the specifications of any of the above listed machines without notice.



The SL-520 vertical cutting machine made by Chudong blends the mature hydraulic cutting structure design data-base and the prospective innovative concepts. The cutting processing adopts mechanical cam structure for stable and smooth operation. The integrated new-type control model digitalizes all production terms and makes their settings storable for easy operation. This not only alters the operating means that changes all parameters of the machine once the items are changed but also cuts the waste and the production line transfer time.